

Steens Industrier A.S

Your Partner in Production

60
Years
1948 - 2008



Steens Physical[®]

World wide medical training equipment

www.steens-industrier.com

post@steens-industrier.com

Post address

P.O. Box 254
N-1401 SKI
Norway

Visiting address

Verkstedveien 25, 1400 SKI
Office hours
08.00 - 15.30 (13.00)

Phone

(+47) 64 91 47 00

Fax

(+47) 64 87 65 47

SmartBike for ClearChannel

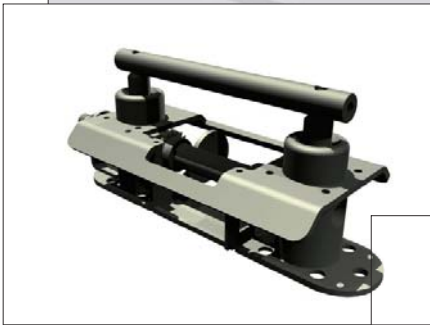

Laser cutting
Sheet bending
Robot welding
Machining of metal

.....

Mail box for POSTEN



Steens Industrier A.S

We are a family business established in 1948. In the beginning we only did chrome plating in a small facility in Oslo. It was 3 employees at the most. Since those years, the company has been thru many processes to be what we are today.

Today, the company is located in Ski, 30 km south of Oslo. The factory is modern and we first came here in 1976. Back then it was 1100 m² and 11 employees. My father and uncle took over the factory after my grandfather died, only 54 years old. Today the factory is 5000 m² and has 32 employees. My father is 64 years old and in 2003 we did a generation change, and it is now the third generation running business. We still get a lot of input from the second generation, but we are steaming ahead at the best of our ability.

”My father still dreams about taking a trip around the world in his sailing yacht, and he uses his means on sailing. My dream is then to be able to say to him: ”take the trip, you have earned it”, within a year or two. Our ability to run the business and future developments will show if this dream is coming thru or not. I really hope it comes thru.”

The company has developed it's own brand in the area of physical- and rehabilitation training apparatus since 1966, and it is sold under the registered brand:

Steens Physical®

75% of this goods is exported to 19 different countries and Denmark, Sweden, Belgium, Japan and USA is the biggest markets besides Norway. We are working thru dealers in all countries since we want to concentrate on production and development as much as possible. Export of these products stands for approximately 35% of our total sales today.

The company is a sub supplier in the area of mechanical making of metal and products in that area. We can mention that we have delivered smartbike systems for Barcelona, Milan, Stockholm, Oslo and other cities thru our customer Clear Channel. We also deliver postboxes for the private market and have a contract with the Norwegian postal services for the years 2007-2010. This order was achieved in cooperation with the designers in Frost Produkt AS in Norway. In addition to this we are a sub supplier for many large Norwegian companies.

We have invested over 15 mill. NOK in new machinery over the last 3 years. This is done to be up to date in the fields which we are operating. This is a considerable amount for a small company like ours. And it is important to motivate our employees which is our most important resource. We are constantly seeking ways of doing our production better, to be able to compete with countries that is not rated as a high cost country, like Norway is.

We have also bought a stake in a Swedish company which operate in the field of sheet metal production. The factory is very modern and has the most up to date machinery in addition to 25 skilled employees. They are delivering parts for a lot of large companies and we are also one of their largest customers. This has given us a foot inside the EU and an opportunity to make parts that doesn't suit our own machinery.

To be able to participate in the marketplace in all the fields we are dependant on a lot of factors, and here are the most important ones: The framework and set of rules for doing business, well skilled employees, information technology as a strength, quality thinking, knowledge of the market, modern machinery, serious customers and dealers, and a management that thinks ahead, can keep a smile on their face and take the decisions needed for every occasion.

We wish all existing customers and new connections welcome to our ”family” and a safe way of doing business, with a partner you can trust. We promise to do our very best keeping you satisfied! If you want more information you can visit our web zite: www.steens-industrier.com

Tommy Steen

Managing director and chairman of Steens Industrier AS.

Steens Industrier *celebrates 60-years anniversary!*

We thank all our customers, dealers and partners for exciting and beneficial development for over 60 years. We are looking forward to rewarding years with more development of products for use in the area of rehabilitation and training, and production in general.

We also wish new customers welcome, and we are looking forward to challenges, projects and orders for us and our modern machinery.

Steens Physical®



The company is approved according to
NS-EN ISO 9001:2000

Steens Industrier A.S

Your Partner in Production

www.steens-industrier.com
www.steens-physical.com
www.steens-physicalusa.com